

FIXED ORIFICE BALL FLOAT STEAM TRAP(FOFT-20H)

TECHNICAL INFORMATION SHEET

CAST IRON

SIZE : 40 AND 50 NB



DESCRIPTION

Volfram Fixed orifice Ball Float Steam Traps(FOFT-20H) are available with air vent and steam lock release. These traps are designed for draining condensate from all types of low & medium pressure steam heating process.

SIZES & CLASS / RATINGS

- Available Sizes : 40NB, 50NB
- End Connection : Screwed

Types : FOFT-20H - 4.5, 10, 14 bar Differential Pressure & Option with SLR / Thermostatic Air Vent

FEATURES

- Discharges condensate from trap at saturated temperature
- Excellent air venting(by thermostatic air vent)



BALL FLOAT STEAM TRAP SCR ENDS (FOFT-20H)

CAPACITY CHART 40/50 NB (kg/hr)

Model		FOFT20H-4.5	FOFT20H-10	FOFT20H-14
Differential Pressure(bar)	0.5	2931	2279	1925
	1	3174	2738	2245
	1.5	3415	2904	2513
	2	3673	2978	2749
	3	4166	3159	2942
	4	4651	3404	3066
	4.5	4904	3485	3144
	5	-	3597	3218
	6	-	3774	3333

CAPACITY CHART 40/50 NB (kg/hr)

Model		FOFT20H-4.5	FOFT20H-10	FOFT20H-14
Differential Pressure(bar)	7	-	4111	3584
	8	-	4492	3848
	9	-	4886	4084
	10	-	5221	4322
	11	-	-	4540
	12	-	-	4747
	13	-	-	4944
	14	-	-	5138

INSTALLATION :

Float Trap must be installed in horizontal position, the float assembly movement must be vertical. Hence the flow direction must be as per shown on body. Before installing trap, the inlet piping should be carefully blown downed to remove any existing pipe debris.

* NOTE : WE RESERVE THE RIGHT TO CHANGE SPECIFICATIONS WITHOUT PRIOR NOTICE FOR THE DEVELOPMENT AND IMPROVEMENT OF THE PRODUCT.



VOLFRAM SYSTEMS INDIA PVT. LTD.

OFFICE ADDRESS : 402, RUTUVIHAR, VARANASI SOCIETY, WARJE, PUNE, 411058
 FACTORY ADDRESS : D II, BLOCK NO. 58&59- 13/14/15, OPP. SPACO CO., SANT
 DYANESHWAR INDUSTRIAL ESTATE, MOHAN NAGAR, MIDC CHINCHWAD, 411019
 Tel.: +91 9309534688 | Email: steam@volfram.in | www.volfram.in

FIXED ORIFICE BALL FLOAT STEAM TRAP(FOFT-20H)

TECHNICAL INFORMATION SHEET

CAST IRON

SIZE : 40 AND 50 NB



BILL OF MATERIAL

Sr. No	Part	Material
01	Body	Cast Iron
02	Cover	Cast Iron
03	Cover Gasket	Asbestos Free Fibre Jointing
04	Valve Seat	SS420
05	Valve	SS304
06	Lever	SS304
07	Float	SS304
08	Air Vent Assembly / SLR	SS304
09	Hex Bolt	High Tensile
10	Gasket Air Vent	Copper
11	Gasket Valve Seat	Copper

OPERATING CONDITIONS

Max. Operating Pressure	Max. Operating Temperature	Hydro Test Pr.
14 Kg/cm ²	220°C	21 Kg/cm ²

DIMENSIONS(mm)

Dimension	Size		
	40 NB	50 NB	
A	232	232	
B	300	300	
C	327	327	
D	S/W	40 NB	50 NB
	SCR	1½" BSP	2" BSP
Approx Weight	25 KG	25 KG	

All dimensions are in mm

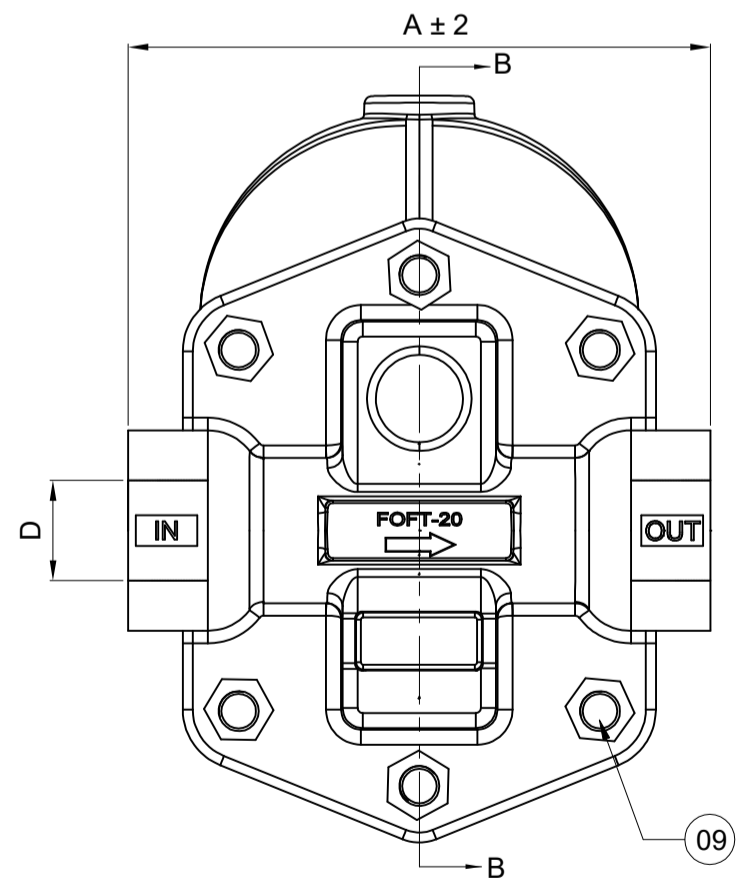
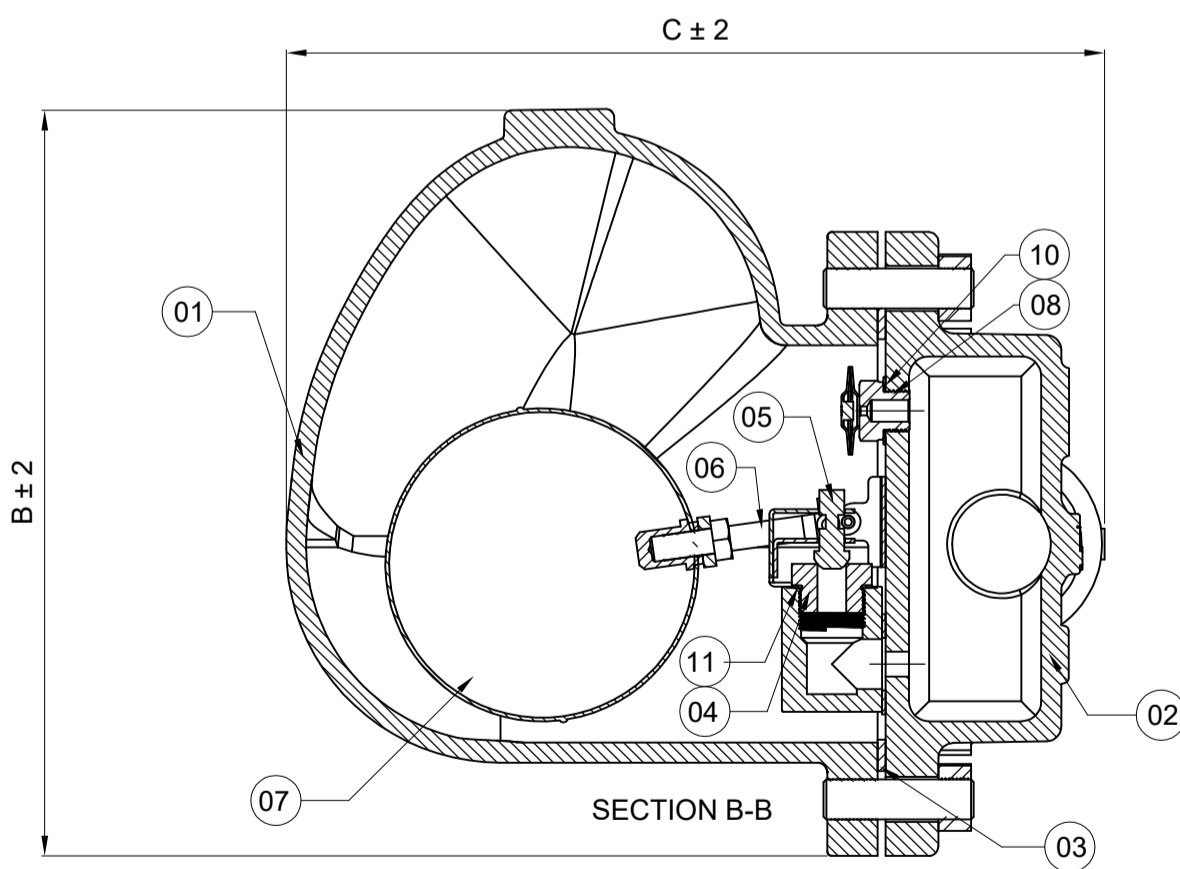

* NOTE : WE RESERVE THE RIGHT TO CHANGE SPECIFICATIONS WITHOUT PRIOR NOTICE FOR THE DEVELOPMENT AND IMPROVEMENT OF THE PRODUCT.

PAGE.: 02 OF 02



VOLFRAM SYSTEMS INDIA PVT. LTD.

OFFICE ADDRESS : 402, RUTUVIHAR, VARANASI SOCIETY, WARJE, PUNE, 411058
 FACTORY ADDRESS : D II, BLOCK NO. 58&59- 13/14/15, OPP. SPACO CO., SANT
 DYANESHWAR INDUSTRIAL ESTATE, MOHAN NAGAR, MIDC CHINCHWAD, 411019
 Tel.: +91 9309534688 | Email: steam@volfram.in | www.volfram.in

V3 OCT 2023