

STEAM INJECTOR (STI - 30)

TECHNICAL INFORMATION SHEET

STAINLESS STEEL
SIZE : 15 NB TO 50 NB



DESCRIPTION

VOLFRAM STEAM INJECTOR IS DESIGNED TO MIX STEAM PROPERLY WITH WATER(OR ANY OTHER LIQUID) TO INCREASE & MAINTAIN THE TEMPERATURE.

SIZES

- AVAILABLE SIZES : 15, 20, 25, 40, 50 NB.

SIZE CHART					WEIGHT (KG)
SIZE(NB)	A(MM)	B(MM)	C	D	
15	112	90	1/2" BSP(F)	Ø48	1.50
20	112	90	3/4" BSP(F)	Ø48	1.50
25	112	90	1" BSP(F)	Ø48	1.70
40	112	90	Ø35	1½" BSP(M)	1.75
50	135	115	Ø45	2" BSP(M)	2.55

* NOTE.: GENERAL TOLERANCE FOR THE DIMENSIONS ± 3 MM.

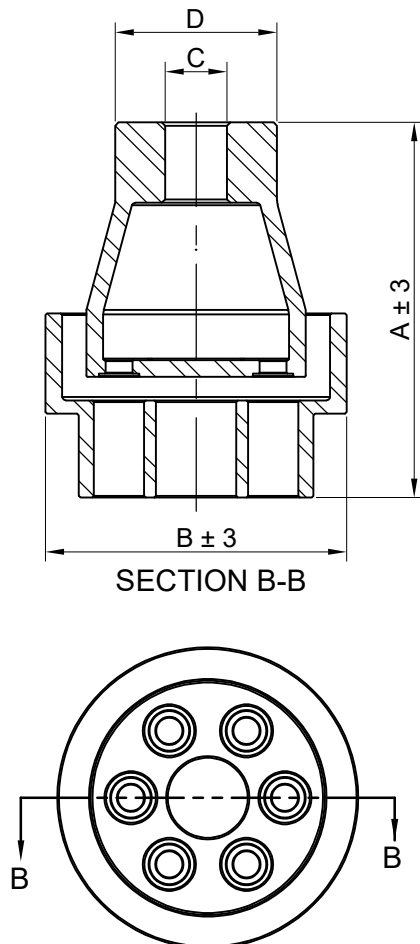

STEAM INJECTOR (STI-30)

SPECIFICATION

- MEDIA : STEAM
- MATERIAL : AUSTENITIC STAINLESS STEEL ASTM A351 CF8 / CF8M
- END CONNECTION : SCREWED
- MAX WORKING PRESSURE: 17 Kg/cm²(g) @ 207°C

STEAM CAPACITY (Kg/hr)

SIZE(NB)▶	STEAM CAPACITY (Kg/hr)				
STEAM PRESSURE BAR(g)▼	15 NB	20 NB	25 NB	40 NB	50 NB
1 bar	18	70	128	372	409
2 bar	43	100	157	522	574
3 bar	59	155	252	724	796
4 bar	75	190	315	873	960
5 bar	91	230	369	1012	1113
6 bar	108	280	450	1165	1282
7 bar	124	321	522	1300	1430
8 bar	140	359	576	1458	1604
9 bar	156	395	630	1638	1802
10 bar	172	427	688	1755	1931

* NOTE.: WE RESERVE THE RIGHT TO CHANGE SPECIFICATIONS WITHOUT PRIOR NOTICE FOR THE DEVELOPMENT AND IMPROVEMENT OF THE PRODUCT.

VOLFRAM SYSTEMS INDIA PVT. LTD.

OFFICE ADDRESS : 402, RUTUVIHAR, VARANASI SOCIETY, WARJE, PUNE, 411058
 FACTORY ADDRESS : D II, BLOCK NO. 58&59- 13/14/15, OPP. SPACO CO., SANT
 DYANESHWAR INDUSTRIAL ESTATE, MOHAN NAGAR, MIDC CHINCHWAD, 411019
 Tel.: +91 9309534688 | Email: steam@volfram.in | www.volfram.in

