

'Y' - TYPE STRAINER (STR-11)

TECHNICAL INFORMATION SHEET

CAST CARBON STEEL (ASTM A216 Gr. WCB)

CLASS / RATING : #150 & #300 | SIZE : 50 NB TO 250 NB



DESCRIPTION

VOLFRAM CAST STRAINERS ARE AVAILABLE IN CAST STEEL ASTM A216 GR. WCB. THESE STRAINERS HAVE VARIETY OF APPLICATION FOR PROCESS INDUSTRY. VOLFRAM STRAINERS ARE PROVIDED WITH MOST MODERN DESIGN AND CONSTRUCTION, IN ACCORDANCE WITH THE LATEST REQUIREMENT OF ASME / IBR STANDARDS.

SIZES & CLASS / RATINGS

- AVAILABLE SIZES : 50NB, 65NB, 80NB, 100NB, 150NB, 200NB, 250NB & ABOVE SIZES AVAILABLE ON REQUEST.
- AVAILABLE CLASS : #150 & #300 (ASME B 16.5)
- END CONNECTION : FLANGED ENDS

CERTIFICATION :

THESE STRAINERS ARE AVAILABLE WITH IBR CERTIFICATION (INDIAN BOILER REGULATIONS).

FEATURES

- MINIMUM PRESSURE DROP INSIDE BODY DUE TO STREAMLINED BODY DESIGN
- STAINLESS STEEL (SS 304) PERFORATED SHEET SCREEN IS GUIDED IN BODY AND COVER.
- SCREEN WITH DIFFERENT SIZES AVAILABLE ON REQUEST.



'Y' - TYPE STRAINER (STR-11)

DIMENSIONS(MM)

Size (NB)	Class #150				Class #300			
	A	B	C	Weight (KG)	A	B	C	Weight (KG)
50	254	212	50 NB	15.4	254	212	50 NB	16.0
65	292	240	65 NB	24.0	292	240	65 NB	25.0
80	330	276	80 NB	30.6	330	276	80 NB	32.0
100	381	321	100 NB	48.6	381	321	100 NB	53.8
150	480	420	150 NB	89	493	420	150 NB	134
200	600	520	200 NB	140	622	520	200 NB	211
250	700	600	250 NB	240	710	600	250 NB	245

ALL DIMENSIONS ARE IN MM(GENERAL TOLERANCE ±5MM)

OPERATING CONDITIONS

RATING	MAXIMUM OPERATING PRESSURE	MAXIMUM OPERATING TEMPERATURE
#150	19.9 Kg/cm ² @ 30°C	425°C @ 5.6 Kg/cm ²
#300	52.1 Kg/cm ² @ 30°C	425°C @ 29.3 Kg/cm ²

HYDRO TEST PRESSURE (AS PER IBR)

#150	29.98 @ 30°C
#300	78.16 @ 30°C

BILL OF MATERIAL

SR. NO.	PARTS	MATERIALS
01	BODY	ASTM A216 WCB
02	COVER	ASTM A216 WCB
03	SCREEN**	SS 304(MESH 40)
04	GASKET**	PURE GRAPHITE WITH TANGE SS316
05	STUD & NUT**	ASTM A 193/194 Gr. B7/2H

NOTE : ** MARKED ITEMS ALSO AVAILABLE AS SPARES.

INSTALLATION :

THE ARROW ON THE CASTING INDICATES FLOW DIRECTION.

SERVICING :

DISMANTLE BOLTED JOINT AND REMOVE STRAINER CAP TO REMOVE MUCK AND CLEAN THE SCREEN THOROUGHLY. FIT THE SCREEN CAREFULLY AND FIT CAP WITH NEW GASKET. TIGHTEN STUD & NUTS UNIFORMLY.

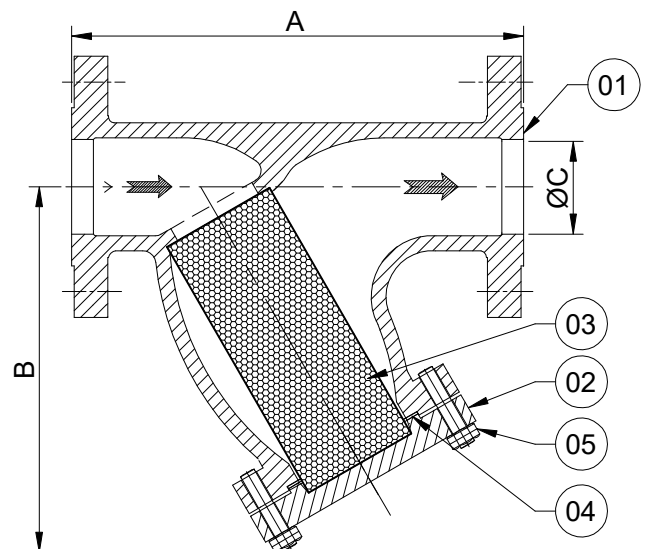

* NOTE.: WE RESERVE THE RIGHT TO CHANGE SPECIFICATIONS WITHOUT PRIOR NOTICE FOR THE DEVELOPMENT AND IMPROVEMENT OF THE PRODUCT. PAGE.: 01 OF 01

VOLFRAM SYSTEMS INDIA PVT. LTD.

OFFICE ADDRESS : 402, RUTUVIHAR, VARANASI SOCIETY, WARJE, PUNE, 411058

FACTORY ADDRESS : D II, BLOCK NO. 58&59- 13/14/15, OPP. SPACO CO., SANT

DYANESHWAR INDUSTRIAL ESTATE, MOHAN NAGAR, MIDC CHINCHWAD, 411019

Tel.: +91 9309534688 | Email: steam@volfram.in | www.volfram.in

