

'Y' - TYPE STRAINER (STR-10)

TECHNICAL INFORMATION SHEET

CAST CARBON STEEL (ASTM A216 Gr. WCB)
CLASS / RATING : #800 | SIZE : 15 NB TO 40 NB



DESCRIPTION

Volfram Cast Strainers are available in cast steel ASTM A216 Gr. WCB. These Strainers have variety of application for process Industries. Volfram Strainers are provided with most modern design and construction, in accordance with the latest requirement of ASME / IBR standards.

SIZES & CLASS / RATINGS

- Available Sizes : 15 NB, 20 NB, 25 NB, 40 NB
- Available Class / Rating : #800
- End Connection : Socket Weld or Screwed Ends (ASME B 16.11)

CERTIFICATION : These Strainers are available with IBR certification (Indian Boiler Regulations).

FEATURES

- Cast Carbon Steel (ASTM A216 Gr. WCB) Body
- Stainless Steel Screen (SS 304)
- Customized Mesh for Screen
- Ability to handle higher pressure
- Compact design & optimized weight.
- Easy to install & maintainance
- Standard end connections as per ASME B 16.11



'Y' - TYPE STRAINER (STR - 10)

BILL OF MATERIAL

Sr. No.	Part	Material
01	Body	ASTM A216 WCB
02	Cap	ASTM A216 WCB
03	Screen**	SS 304(MESH 40)
04	Gasket**	Pure Graphite

NOTE : ** Marked items also available as spares.
Screen with different sizes available on request.

DIMENSIONS(MM)

SIZE (NB)	A	B	C		APPROX WEIGHT (KG)
			SCREWED	SW	
15	82	60	1/2" BSP/NPT	15 NB	1.0
20	85	70	3/4" BSP/NPT	20 NB	1.2
25	100	85	1" BSP/NPT	25 NB	2.0
40	130	105	1 1/2" BSP/NPT	40 NB	3.0

All dimensions are in mm(General Tolerance ±2mm)

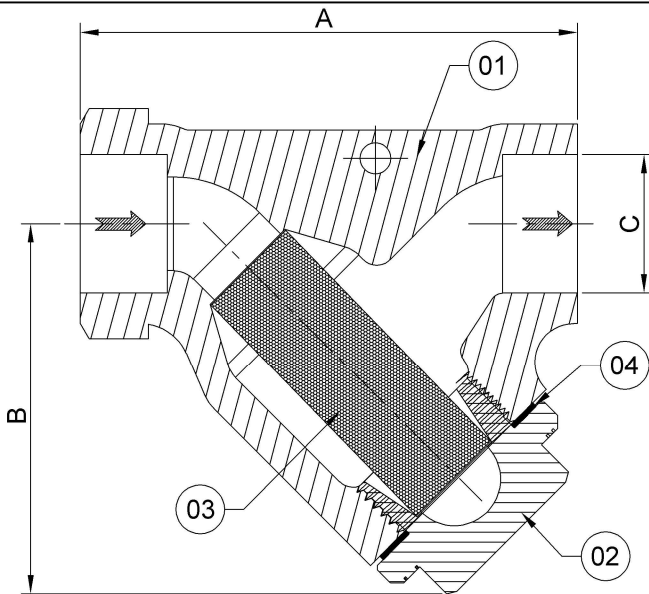

OPERATING CONDITIONS

Type	Maximum Operating Pressure	Maximum Operating Temperature
S/W	138 Kg/cm ² @ 30°C	425°C @ 78.2 Kg/cm ²
SCR	31.5 Kg/cm ² @ 425°C	425°C @ 31.5 Kg/cm ²

INSTALLATION :

The strainer should be installed in the direction of flow, as indicated on its body. Suitable isolation valves must be installed to allow safe maintenance and screen replacement in liquid systems. The pocket should point downwards.

SERVICING :

Dismantle and remove strainer cap to remove muck and clean the screen thoroughly. Fit the screen carefully and Tighten the cap.

* NOTE.: WE RESERVE THE RIGHT TO CHANGE SPECIFICATIONS WITHOUT PRIOR NOTICE FOR THE DEVELOPMENT AND IMPROVEMENT OF THE PRODUCT.

VOLFRAM SYSTEMS INDIA PVT. LTD.

OFFICE ADDRESS : 402, RUTUVIHAR, VARANASI SOCIETY, WARJE, PUNE, 411058
FACTORY ADDRESS : D II, BLOCK NO. 58&59- 13/14/15, OPP. SPACO CO., SANT DYANESHWAR INDUSTRIAL ESTATE, MOHAN NAGAR, MIDC CHINCHWAD, 411019
Tel.: +91 9309534688 | Email: steam@volfram.in | www.volfram.in

